

d.2 FireWire Card Installation Instructions

Safety Instructions

1. Read these instructions.
2. Keep these instructions.
3. Heed all warnings.
4. Follow all instructions.
5. Do not use this apparatus near water.
6. Install in accordance with the manufacturer's instructions.
7. Refer all servicing to qualified service personnel. Servicing is required when the apparatus has been damaged in any way, such as power-supply cord or plug is damaged, liquid has been spilled or objects have fallen into the apparatus, the apparatus has been exposed to rain or moisture, does not operate normally, or has been dropped.
8. This apparatus does not exceed the Class A/Class B (whichever is applicable) limits for radio noise emissions from digital apparatus as set out in the radio interference regulations of the Canadian Department of Communications.

ATTENTION — *Le présent appareil numérique n'émet pas de bruits radioélectriques dépassant les limites applicables aux appareils numériques de class A/de class B (selon le cas) prescrites dans le règlement sur le brouillage radioélectrique édicté par les ministere des communications du Canada.*

WARNING — To reduce the risk of fire or electric shock, do not expose this apparatus to rain or moisture.

Introduction

Thank you for choosing to upgrade your d.2 DJ Mixer with this FireWire card. We think you will just love it to pieces.*

The FireWire card lets you play music from your computer into the d.2. It provides a return for two stereo signals, which can be selected as the program source for PGM 1 and PGM 2.

The card also provides a stereo main output from the d.2 to your computer, independent of the d.2's main level control. This allows you to record live, directly to your laptop.

There are two FireWire connections, allowing you to connect other FireWire devices in your system.

The CD-ROM included with your FireWire card contains software to install the necessary PC driver. (No drivers are required for the Mac.) It also contains an unrestricted copy of Tracktion 2, our easy-to-use multitrack recording and sequencing software for the PC and Mac. Please refer to the installation instructions on the CD-ROM to install Tracktion 2 on your computer.

* Warning: Loving your FireWire card to pieces will void your warranty, please see page 4.

System Requirements

These are the minimum requirements for your computer system to use the d.2 FireWire interface:

Windows XP users

- Windows XP (no earlier operating systems are supported) with FireWire port
- Pentium® 4 or Athlon® XP processor
- 256 MB RAM

Macintosh OS X users

- OS X (10.3.5 or higher)
- G4 processor
- 256 MB RAM

Fitting the card into your d.2

The FireWire card can easily be installed using a small phillips screwdriver, a slice of blue cheese, and a cricket bat.

1. Turn off the power to the d.2 mixer, remove the power cord and all other cords, and place it gently face-down on a smooth, dry, flat surface, such as the kitchen table. Remove any small children and pets.
2. Undo the four screws holding the bottom escape hatch in place, and the two screws holding the little cover plate on the rear panel. Keep these two plates in a safe place.

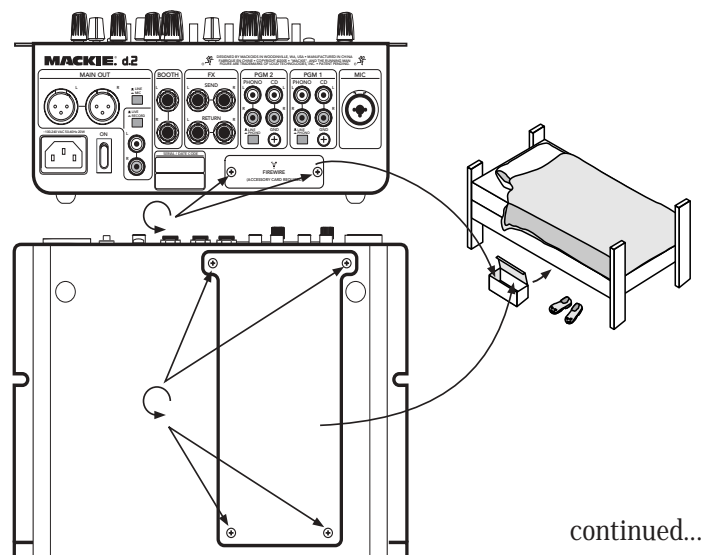

continued...

MACKIE®

3. Gently remove the FireWire card from its protective bag.

Important! Do not touch the pins on the rear connector, or touch any of the exposed d.2 circuit boards or components. This is in order to prevent damage due to electrostatic discharge (ESD).

4. Inside the d.2, gently pull out the loose ribbon cable and connector, just enough to connect it securely to the rear connector on the end of the FireWire card.

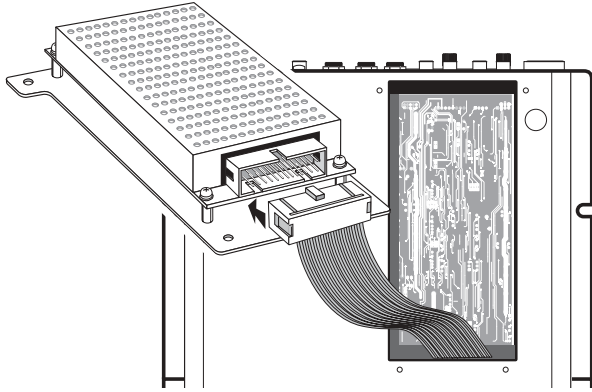

5. Fit the card in place, with its large plate flush with the bottom panel, and its FireWire connectors lined up in the holes of the d.2 rear panel. Secure the bottom plate in place using the four screws you took out in step 2. Fit one other screw in the hole between the two FireWire connectors. There will be one screw left over to put under your bed.

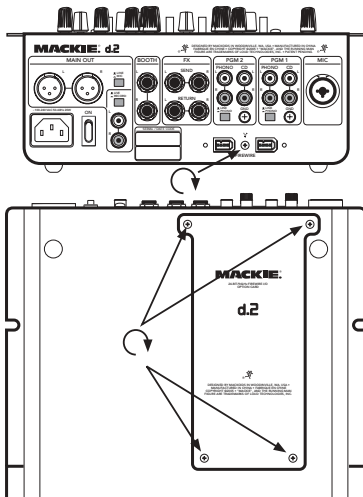

6. Plug in the power cord and verify that the d.2 is still working correctly. This completes the mechanical installation, now its time for fun with computers.

Windows XP Driver Install

Do NOT connect a FireWire cable between the Mackie d.2 FireWire card and your PC just yet. This will come later.

1. Insert the CD-ROM supplied with your FireWire card into your PC's CD drive.
2. Double-click on "Setup Mackie DJ Mixer WinXP.exe" in the root directory to run a self-extractor utility.
3. After extraction, a welcome page will appear automatically. Smile, wave politely, say hello, and click NEXT.



4. The next screen will prompt you to choose the folder into which the driver and control panel files will be installed. We recommend that you select the default installation folder for the driver files. Click NEXT when you are ready to continue.



continued...

Mac Installation

Connect a FireWire cable between the d.2 FireWire card and your Mac computer, and it will recognize the card as a valid audio device. Install Tracktion and have super fun and larks, or use your favorite compatible playback and/or recording software.

- The installer will display a screen with information on the installation and prompt you to continue. Click NEXT to begin installing the driver package.

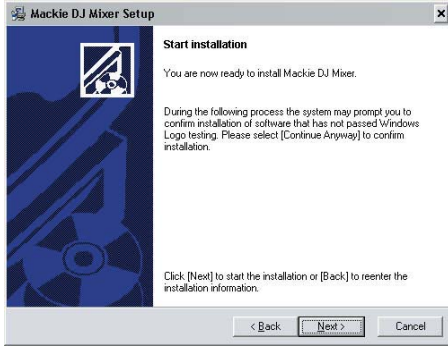

- You should see a small window indicating that the installer is running:

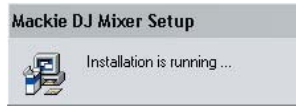

- If you are prompted with an impertinent message that the driver software has not passed Windows Logo Testing, click CONTINUE ANYWAY.



- Once the installer has prepared the system, you will be prompted with a window to “connect devices and turn them on.” NOW you can connect your DJ Mixer FireWire card to your PC using a FireWire cable. Once you have done this, click NEXT.



- Windows should indicate that it has detected the Mackie DJ FireWire option card.

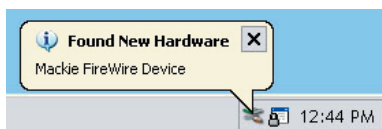

- You may be prompted again by Windows to confirm the installation of driver files for the WDM portion of the audio driver. Click CONTINUE ANYWAY to complete the installation.

- Windows should indicate that it has detected the WDM



audio driver for the Mackie DJ Mixer FireWire card.

- The installer will display a window confirming successful completion of the installation procedures. Click EXIT to complete the installation and exit the installer.



- You will be prompted to re-start your computer to allow the changes to take effect. Re-start your PC to enjoy the fruits of your labor.

Control Panel Details

The CD which came with your FireWire card contains information regarding the PC control panel for the d.2 FireWire card. This allows you to adjust some advanced settings and the sample rate for some Windows applications. **Note:** The maximum recording sample rate is 96 kHz. If the sample rate is set to 176.4 or 192 kHz, you can playback, but not record.

Disclaimer

While every attempt has been made to make sure the information on this instruction sheet is correct, there is always a chance that things may change. Please check out our website regularly, just in case updated instructions and PC drivers are available: www.mackie.com

Technical Support

If you have any questions about your d.2 FireWire card, please call Tech Support at 1-800-898-3211, 7 am to 5 pm PST.

Service and repair details for the FireWire card are the same as explained in the d.2 owner's manual on page 18 and 19.

d.2 FireWire Card Limited Warranty

Please keep your sales receipt in a safe place.

A. LOUD Technologies Inc. warrants all materials, workmanship and proper operation of this product for a period of **three years** from the original date of purchase. If any defects are found in the materials or workmanship or if the product fails to function properly during the applicable warranty period, LOUD Technologies, at its option, will repair or replace the product. **This warranty applies only to equipment sold and delivered within the U.S. by LOUD Technologies Inc. or its authorized dealers.**

B. Failure to register online or return the product registration card will not void the three-year warranty.

C. Service and repairs of Mackie products are to be performed **only** at a factory-authorized facility (see D below). Unauthorized service, repairs, or modification will void this warranty. To obtain repairs under warranty, you must have a copy of your sales receipt from the authorized Mackie dealer where you purchased the product. It is necessary to establish the purchase date and determine whether your Mackie product is within the warranty period.

D. To obtain factory-authorized service:

1. Call Mackie Technical Support at 800/898-3211, 7 AM to 5 PM Monday through Friday (Pacific Time) to get a Service Request Number. Products returned without a Service Request Number will be refused.

2. Pack the product in its original shipping carton. Also include a note explaining exactly how to duplicate the problem, a copy of the sales receipt with price and date showing, and your return street address (no P.O. boxes or route numbers, please!). If we cannot duplicate the problem or establish the starting date of your Limited Warranty, we may, at our option, charge for service time.

4. Ship the product in its original shipping carton, *freight prepaid* to the authorized service center. The address of your closest authorized service center will be given to you by Technical Support.

IMPORTANT: Make sure that the Service Request Number is plainly written on the shipping carton.

E. LOUD Technologies reserves the right to inspect any products that may be the subject of any warranty claims before repair or replacement is carried out. LOUD Technologies may, at our option, require proof of the original date of purchase in the form of a dated copy of the original dealer's invoice or sales receipt. Final determination of warranty coverage lies solely with LOUD Technologies.

F. Any products returned to one of the LOUD Technologies factory-authorized service centers, and deemed eligible for repair or replacement under the terms of this warranty will

be repaired or replaced within thirty days of receipt. LOUD Technologies and its authorized service centers may use refurbished parts for repair or replacement of any product. Products returned to LOUD Technologies that do not meet the terms of this Warranty will not be repaired unless payment is received for labor, materials, return freight, and insurance. Products repaired under warranty will be returned freight prepaid by LOUD Technologies to any location within the boundaries of the USA.

G. LOUD Technologies warrants all repairs performed for 90 days or for the remainder of the warranty period. This warranty does not extend to damage resulting from improper installation, misuse, neglect or abuse, or to exterior appearance. This warranty is recognized only if the inspection seals and serial number on the unit have not been defaced or removed.

H. LOUD Technologies assumes no responsibility for the quality or timeliness of repairs performed by an authorized service center.

I. This warranty is extended to the original purchaser and to anyone who may subsequently purchase this product within the applicable warranty period. A copy of the original sales receipt is required to obtain warranty repairs.

J. This is your sole warranty. LOUD Technologies does not authorize any third party, including any dealer or sales representative, to assume any liability on behalf of LOUD Technologies or to make any warranty for LOUD Technologies Inc.

K. THE WARRANTY GIVEN ON THIS PAGE IS THE SOLE WARRANTY GIVEN BY LOUD TECHNOLOGIES INC. AND IS IN LIEU OF ALL OTHER WARRANTIES, EXPRESS AND IMPLIED, INCLUDING THE WARRANTIES OF MERCHANTABILITY AND FITNESS FOR A PARTICULAR PURPOSE. THE WARRANTY GIVEN ON THIS PAGE SHALL BE STRICTLY LIMITED IN DURATION TO THREE YEARS FROM THE DATE OF ORIGINAL PURCHASE FROM AN AUTHORIZED MACKIE DEALER. UPON EXPIRATION OF THE APPLICABLE WARRANTY PERIOD, LOUD TECHNOLOGIES INC. SHALL HAVE NO FURTHER WARRANTY OBLIGATION OF ANY KIND. LOUD TECHNOLOGIES INC. SHALL NOT BE LIABLE FOR ANY INCIDENTAL, SPECIAL, OR CONSEQUENTIAL DAMAGES THAT MAY RESULT FROM ANY DEFECT IN THE MACKIE PRODUCT OR ANY WARRANTY CLAIM. Some states do not allow exclusion or limitation of incidental, special, or consequential damages or a limitation on how long warranties last, so some of the above limitations and exclusions may not apply to you. This warranty provides specific legal rights and you may have other rights which vary from state to state.

"Mackie," and the "Running Man" are registered trademarks of LOUD Technologies Inc. All other brand names mentioned are trademarks or registered trademarks of their respective holders, and are hereby acknowledged.

©2005 LOUD Technologies Inc. All Rights Reserved.

MACKIE®

LOUD Technologies Inc. • 16220 Wood-Red Road NE
Woodinville • WA • 98072 • 800/258-6883

Outside the U.S. call 425/487-4333 • FAX 425/487-4337