

# HOOKUP DIAGRAMS

## Quick-Start

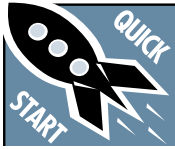

Make all initial connections with the power switches OFF on all equipment. Make sure all master volume, level, or gain controls are all the way down.

1. Connect the line-level outputs from your mixing console (or other signal source) to the inputs of your power amplifier.
2. Connect the "Speaker Output" from your power amplifier (or powered mixer) to the INPUT connector on the S215.
3. Turn on your mixing console (or other signal source).
4. Turn on the amplifier. Turn up its volume or gain control(s) as recommended by the manufacturer.
5. Start the signal source, whether it be speaking into a microphone or starting a CD player. Adjust the volume controls on the mixer (or other signal source) for normal operation.

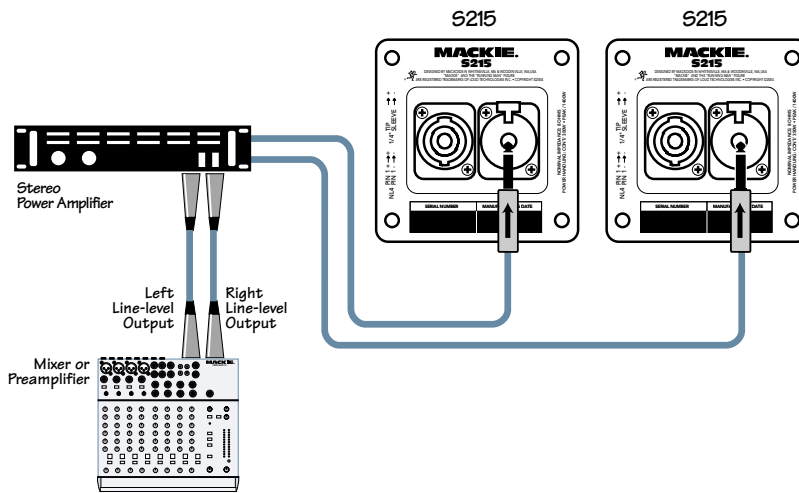

**S215: WITH A MIXER AND POWER AMPLIFIER**

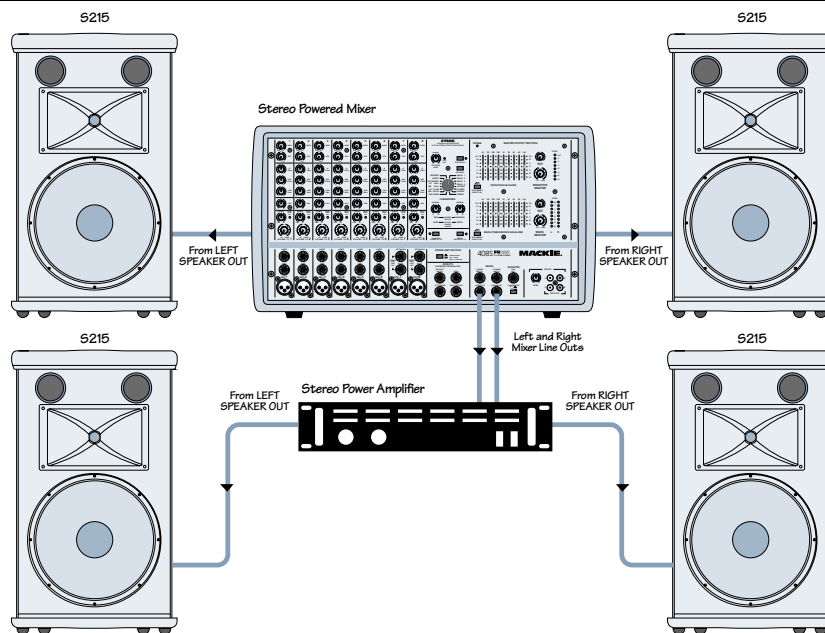

**S215: WITH A MACKIE POWERED MIXER AND STEREO POWER AMPLIFIER**

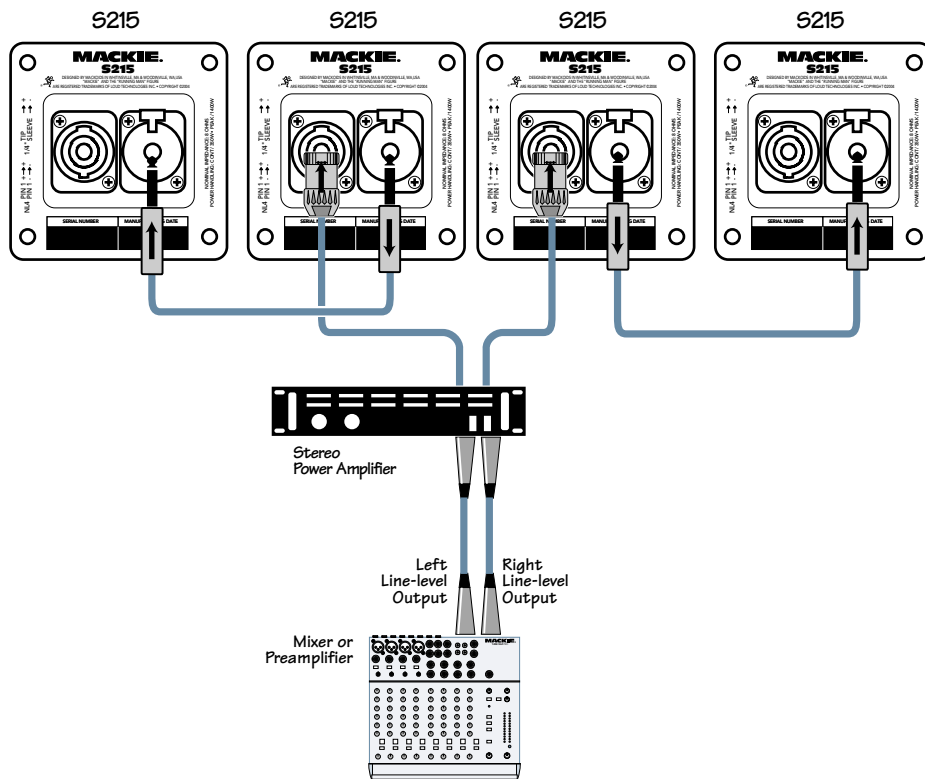

### S215: WITH A MIXER AND POWER AMPLIFIER, USING THE 1/4" THRU JACKS

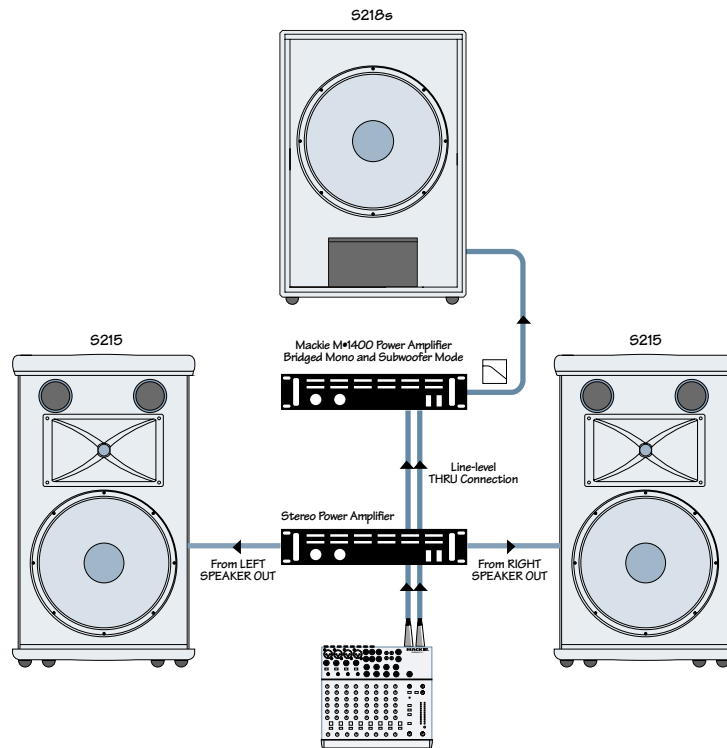

**Note:** The FR Series M•1400 power amplifiers have a built-in subwoofer crossover. If you are not using a Mackie M•1400 amplifier, you can use an active crossover between the first and second amplifiers with the crossover set between 125 Hz to 180 Hz. This allows more amplifier power for the low frequencies rather than being wasted as heat in the S218s' internal built-in crossover.

### S215: WITH A MIXER, TWO POWER AMPLIFIERS, AND AN S218s SUBWOOFER